



EM *Eminoğlu Machinery*

📍 Akçaburgaz Mah. 3028 Sok. No: 1/9.
Esenyurt / İstanbul - Türkiye

☎ +90 212 549 81 76

☎ +90 212 549 81 75

✉ info@eminoglumakina.com
serdarkayaaslan@gmail.com

www.eminoglumakina.com



ONLINE CATALOG

🌐 eminoglumachinery
📷 eminoglumakina
🐦 eminoglumakina

✓
**CHOCOLATE
MACHINES**
ÇİKOLATA
MAKİNALARI

EM *Eminoğlu Machinery*



www.eminoglumakina.com



▼
**CHOCOLATE
MACHINES**
ÇİKOLATA
MAKİNALARI

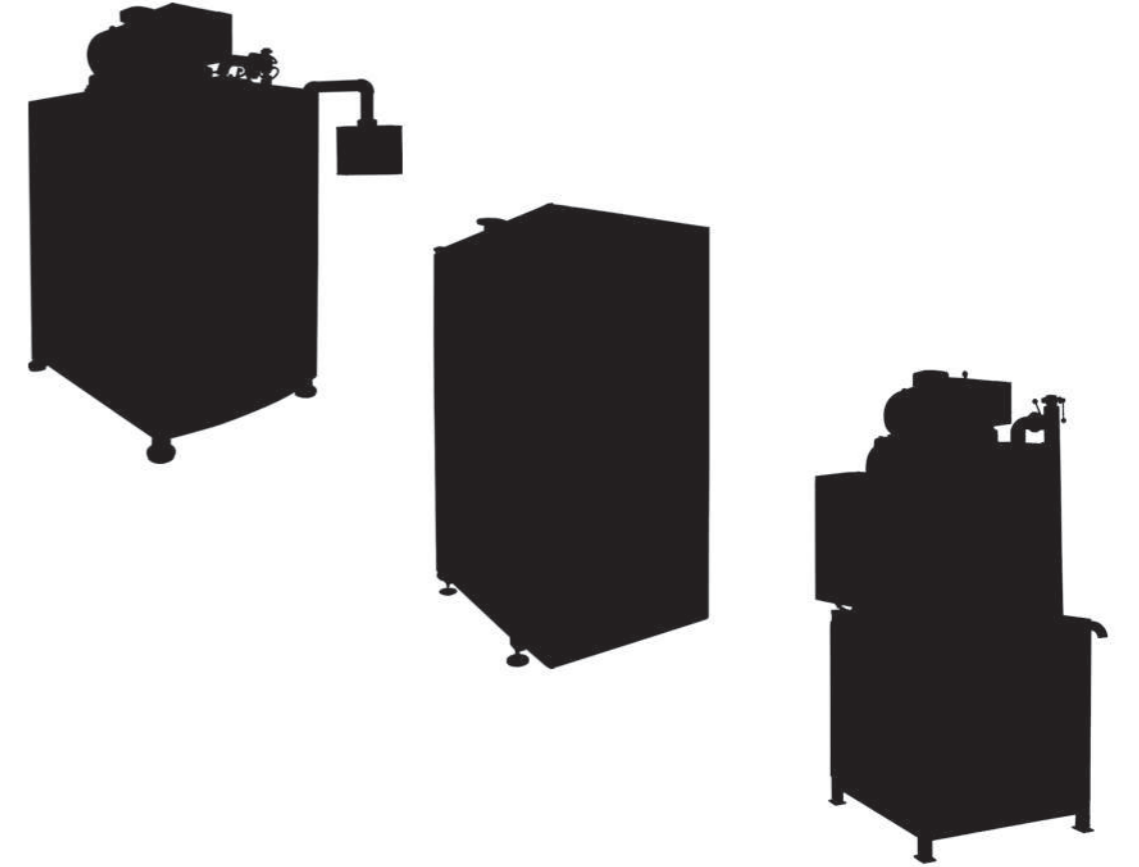



OUR CHOCOLATE MOLD SUPPLIER

ÇİKOLATA KALIBI TEDARİKÇİMİZ





EMİNOęLU IKOLATA MAKİNALARI
EMİNOęLU CHOCOLATE MACHINES

www.eminoglumakina.com



EMİNOĞLU ÇİKOLATA MAKİNALARI

Firmamız 2001 yılında kurulmuş olup çikolata ile ilgili bir çok projeye başarılı bir şekilde imzasını atmıştır. Türkiye’de çikolatanın sadece büyük fabrikalarda değil; küçük, az sermayeli atölyelerde de üretebileceğini piyasaya gösterdiği gibi çok büyük anahtar teslim çikolata fabrikalara projelerine de imzasını atmıştır.

Kaliteden ödün verilmediği sürece Dünya Markası olunabileceğini bilen firmamız bu görüşle yolunda emin adımlarla devam etmektedir.

EMİNOĞLU CHOCOLATE MACHINES

Having been founded in 2001, our firm has successfully carried out so many projects about chocolate since that time. Showing to market that chocolate in Turkey cannot be done only by big producers but also can be done by small ateliers with minimum capitals, our firm has made a lot of successful and big turnkey projects.

As we know that being a World Brand requires no compromising on the quality; we are, positively, walking through our way with this notion.





YURTDIŐI REFERANSLARIMIZ

OUR OVERBOARD REFERENCES

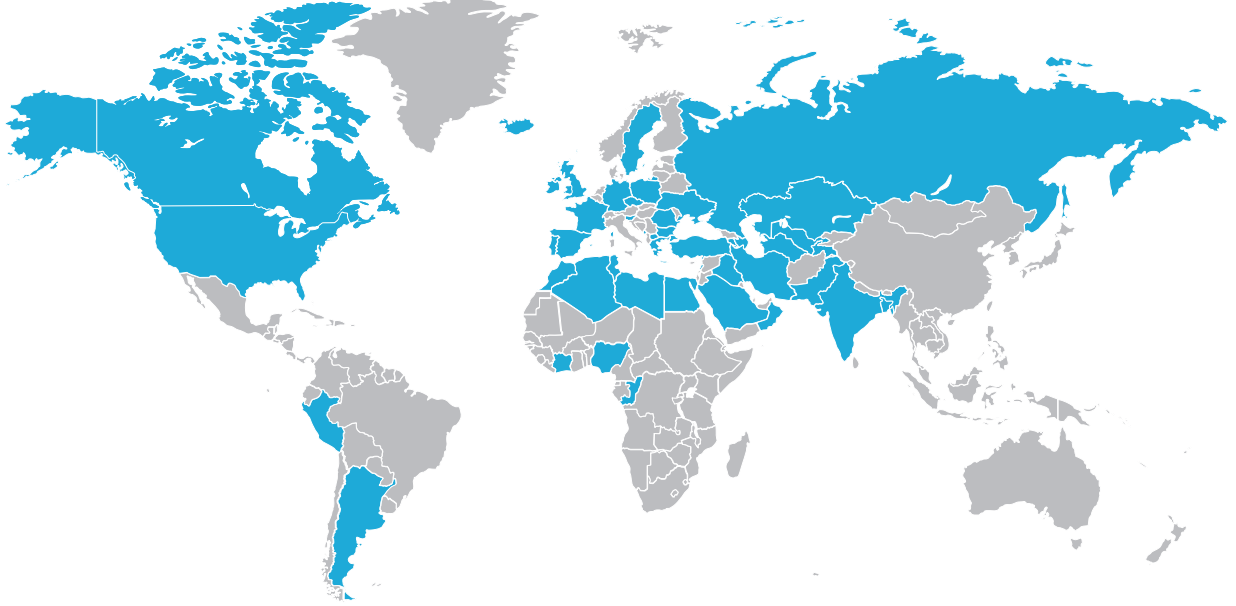

Azerbaycan



Bangladeő



Fas



Ermenistan



Rusya



Özbekistan



Almanya



Yunanistan



Hindistan



İran



İzlanda



Pakistan



Portekiz



Suudi Arabistan



Tacikistan



Türkmenistan



İngiltere



Amerika



Makedonya



Irak



Lübnan



Peru



Romanya



Polonya



Kosova



Tunus



Arjantin



Bulgaria



Ürdün



Kongo



Ukrayna



Kazakistan



Litvanya



İspanya



Senegal



Macaristan



Libya



Sırbistan



Galler



Nijerya



Mısır



İsveç



Fil Diői Sahili



Fransa



Kanada



Cezayir



Avustralya



Meksika



Birleşik Arap Emirlikleri



Avusturya



İrlanda



Umman



Çekya

REFERANSLARIMIZ / OUR REFERENCES





ÇİKOLATA ÖN HAZIRLAMA MİKSERİ CHOCOLATE PREPARATION MIXER



► Teknik Çizim / Technical Drawing

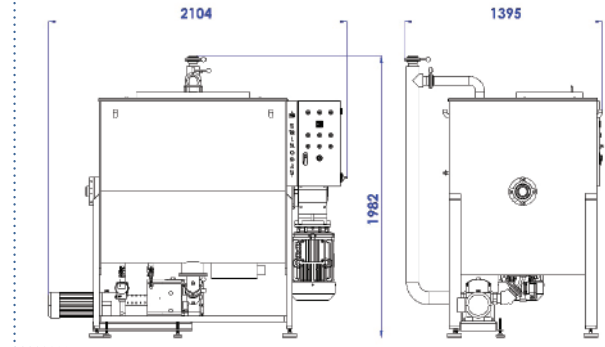

TEKNİK ÖZELLİKLERİ

Kapasite: 1 Ton (İstenilen Kg'da imalat)

Çikolata ile temas eden bütün yüzeylerde 304 kalite paslanmaz çelik

4.5 kw mikser motoru, 7.5 kw ısıtma gücü

Çift cidar sistemi ile ısıtma

TECHNICAL INFORMATION

Capacity: 1 Tonne (Desired KG of production)

All surfaces in contact with chocolate are 304 quality stainless steel

4.5 kw mixer motor, 7.5 kw heating power

Heating with double jacket system



YAĞ ERİTME KAZANI FAT MELTING TANK



► Teknik Çizim / Technical Drawing

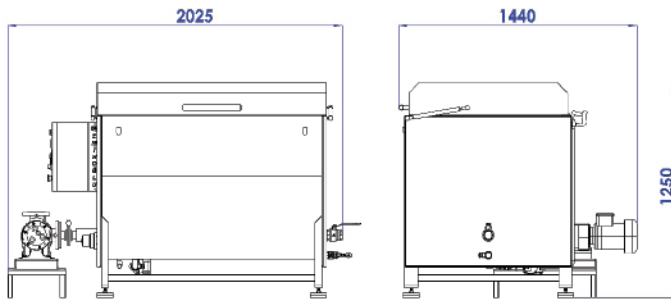

TEKNİK ÖZELLİKLERİ

Kapasite: 300 - 3000 kg

Serpantinli eritme sistemi

Çift cidarlı ısıtma sistemi

TECHNICAL INFORMATION

Capacity: 300 - 3000 kg

Melting system with serpentine

Heating with double jacket system

BİLYALI ÇİKOLATA DEĞİRMENİ CHOCOLATE BALL MILL



15 KG

500 KG



► Teknik Çizim / Technical Drawing

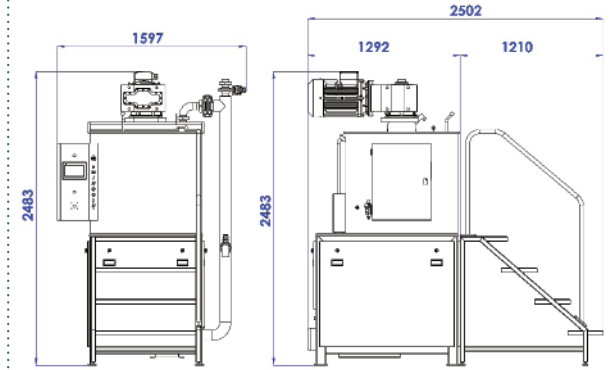

TEKNİK ÖZELLİKLERİ

Çift cidarlı ısıtma - soğutma sistemi

Çikolata devir daim sistemi

Otomatik sıcaklık kontrolleri

Tamamen PLC kontrol sistemi

TECHNICAL INFORMATION

Heating - cooling with double jacket system

Chocolate recirculating pump

Automatic temperature controls

Full PLC control system

KRİSTAL ŞEKERLE ÇALIŞMA RAHATLIĞI

1000 KG



BİLYALI ÇİKOLATA DEĞİRMENİ CHOCOLATE BALL MILL

► Teknik Çizim / Technical Drawing

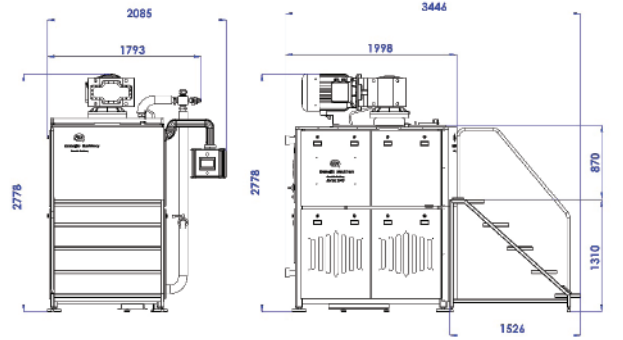

TEKNİK ÖZELLİKLERİ

Çift cidarlı ısıtma - soğutma sistemi

Çikolata devir daim sistemi

Otomatik sıcaklık kontrolleri

Tamamen PLC kontrol sistemi

TECHNICAL INFORMATION

Heating - cooling with double jacket system

Chocolate recirculating pump

Automatic temperature controls

Full PLC control system



THE EASE OF WORKING WITH CRYSTAL SUGAR

FINDIK KREMASI DOLUM MAKİNASI NUT CREAM FILLING MACHINE

KASE DOLUM MAKİNASI BOWL FILLING MACHINE

Pratik, Etkin, Kullanışlı
Practical, Effective, Convenient





ÇİFT RENK PLUS TWO-COLOR PLUS

TEKNİK ÖZELLİKLERİ

Çift cidarlı ısıtma - soğutma sistemi

Servo kontrollü şekil verme ünitesi

Otomatik sıcaklık kontrolleri

Tamamen PLC Kontrol sistemi

TECHNICAL INFORMATION

Heating - cooling with double jacket system

Servo controlled forming unit

Automatic temperature controls

Full PLC control system



500 KG

500 KG ÇİKOLATA TEMPERLEME MAKİNASI 500 KG CHOCOLATE TEMPERING MACHINE



TEKNİK ÖZELLİKLERİ

Çikolata kapasitesi pompa yardımı ile ayarlanabilir.

Çikolata ısı kontrolleri birbirinden bağımsız 4 zone'dan oluşur.

Çikolata sıcaklıkları PLC ekranında ayarlanır.

Mikser motoru mevcuttur.

Sistem toplam 9 kattan oluşmaktadır.

Sistem kendi sıcak suyunu kendi üretir.

5-10 derece arasındaki soğuk su işletme tarafından temin edilir.

Hem çikolata hem su sıcaklık kontrol sistemleri

Basınç emniyet sistemi mevcuttur.

Temper bozucu sistemi mevcuttur.

İşletmeden gelen suyu kendi suyu ile karıştırılmaz; plakalı eşanjör mantığı ile çalışır.

TECHNICAL INFORMATION

Chocolate capacity can be arranged with the help of the pump.

Chocolate heat controls are consist of 4 independent zones.

Chocolate temperatures are arranged via PLC screen

Mixer motor

The system has 9 plates at all.

The system produces its own hot water.

Cold water between 5-10 degrees is maintained by the enterprise.

Heat control system both for chocolate and the water.

Pressure security system.

Temper breaking (Detempering) system

It does not mix the water coming from the enterprise with its own water; works with understanding of plated exchanger.

1000 KG

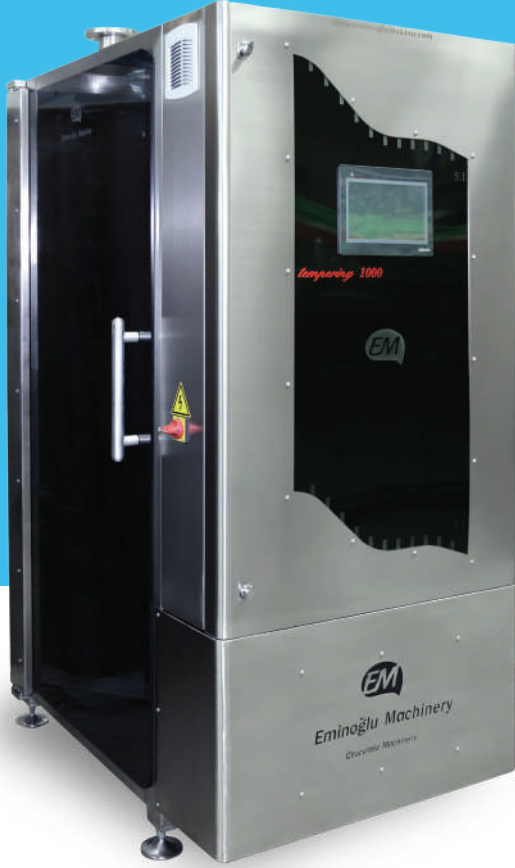

1000 KG ÇİKOLATA TEMPERLEME MAKİNASI

1000 KG CHOCOLATE TEMPERING MACHINE

TEKNİK ÖZELLİKLERİ

Çikolata kapasitesi pompa yardımı ile ayarlanabilir.

Çikolata ısı kontrolleri birbirinden bağımsız 4 zone'dan oluşur.

Çikolata sıcaklıkları PLC ekranında ayarlanır.

Mikser motoru mevcuttur.

Sistem toplam 12 kattan oluşmaktadır.

Sistem kendi sıcak suyunu kendi üretir.

5-10 derece arasındaki soğuk su işletme tarafından temin edilir.

Hem çikolata hem su sıcaklık kontrol sistemleri

Basınç emniyet sistemi mevcuttur.

Temper bozucu sistemi mevcuttur.

İşletmeden gelen suyu kendi suyu ile karıştırılmaz; plakalı eşanjör mantığı ile çalışır.

TECHNICAL INFORMATION

Chocolate capacity can be arranged with the help of the pump.

Chocolate heat controls are consist of 4 independent zones.

Chocolate temperatures are arranged via PLC screen

Mixer motor

The system has 12 plates at all.

The system produces its own hot water.

Cold water between 5-10 degrees is main-tained by the enterprise.

Heat control system both for chocolate and the water.

Pressure security system.

Temper breaking (Detempering) system

It does not mix the water coming from the enterprise with its own water; works with understanding of plated exchanger.

TEK DEPOZİTÖRLÜ ONE SHOT ÇİKOLATA DOLUM MAKİNASI SINGLE DEPOSITOR ONE SHOT CHOCOLATE FILLING MACHINE



TEKNİK ÖZELLİKLERİ

Servo kontrollü dolum sistemi

Özel depositor tasarımı

Ergonomik tasarım ile az alanda çok iş imkanı

Gerçek çikolataya uygun ısıtma-soğutma sistemi

Kalıp ısıtma sistemi

Kalıp vibrasyon sistemi

TECHNICAL INFORMATION

Servo controlled filling system

Special depositor design

Many work opportunities in less space with the help of ergonomic design

Heating - Cooling system for the real chocolate

Mould heating system

Mould vibration system



ÇİFT DEPOZİTÖRLÜ ONE SHOT ÇİKOLATA DOLUM MAKİNASI DOUBLE DEPOSITOR ONE SHOT CHOCOLATE FILLING MACHINE

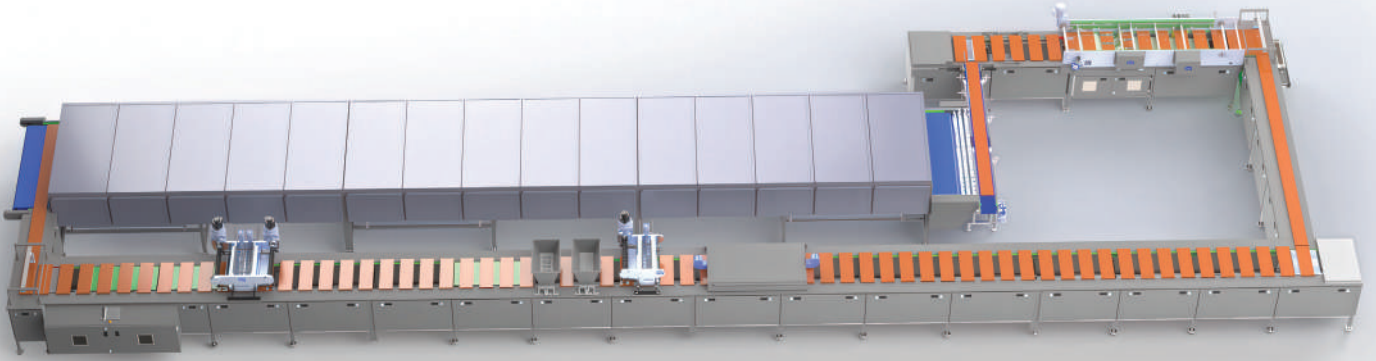

TEKNİK ÖZELLİKLERİ

Her biri çift hazneli bağımsız eksen kontrollü enjeksiyon ünitesi

Sıcaklık kontrollü giriş kalıp kondisyonlama

Bağımsız iki vibrasyon ünitesi

Otomatik mamül dolumu ve seviye kontrolü

Dokunmatik ekran ve PLC

Opsiyonel entegre edilebilir dolgu veya mamül robotu

TECHNICAL INFORMATION

Injection unit, each one with double-chamber and with an independent axis control

Temperature-controlled input mould conditioning

Independent two vibration units

Automatic product filling and level control

Touch screen and PLC

Filling product robot which can be integrated as optional

ÇIKOLATA SOĐUTMA TÜNELLERİ CHOCOLATE COOLING TUNNELS

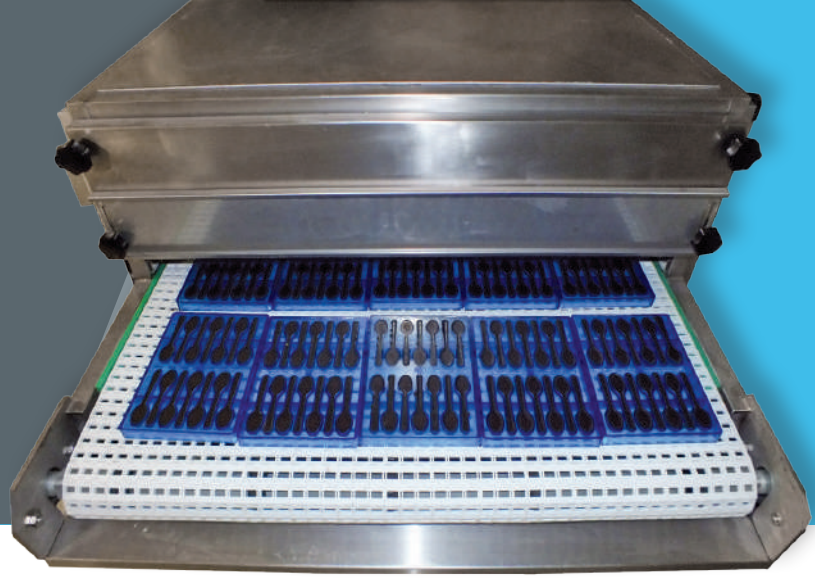

TEKNİK ÖZELLİKLERİ

Tamamen paslanmaz imalat

Gıdaya uygun modüler bant sistemi

Genişlik 1300mm - Boy: 1400mm

3 noktadan hava sirkülasyonu

5 dereceye kadar sođutma kapasitesi

Dolum makinası ile otomasyon sistemi

TECHNICAL INFORMATION

Completely stainless production

Modular conveyor system appropriate for the food

The width is 1300mm - The height is 1400mm

Air circulation from 3 points

Capacity of cooling until 5 celcius degree

Automation system with the filling machine

SPINNER - 3 BOYUTLU ÇİKOLATA MODEL MAKİNASI

SPINNER - 3D CHOCOLATE MODEL MACHINE



**Üç boyutlu çikolata
yapmak artık çok kolay!**

*Now, it is very easy to
make 3D chocolate!*

DRAJE KAZANLARI DRAGEE COATING PANS



TEKNİK ÖZELLİKLERİ

80 - 100 - 120'lik ebatlarda seçimler

Hız kontrol sistemleri

Şartlandırılmış draje odaları

20 KG'dan 300 KG'a kadar üretim imkanı

TECHNICAL INFORMATION

Option on sizes 80 - 100 - 120

Speed control systems

Conditioned dragee rooms

Production opportunity from 20 KG to 300 KG

DRAJE ODALARI DRAGEE COATING ROOM



**SMART DRAJE
ÜRETİM TESİSİ**
SMART DRAGEE
PRODUCTION
FACILITY



SMART DRAJE ÜRETİM TESİSİ SMART DRAGEE PRODUCTION FACILITY



TEKNİK ÖZELLİKLERİ

200 KG / Saate kadar üretim kapasitesi

Küçük, büyük ve istenilen şekle göre bonibon üretim seçenekleri

-25 dereceye kadar soğutma ünitesi

Çekirdeklenmeden sonra soğutma tüneli ve çapaklama istasyonu

Profesyonel ve kaliteli smart üretim

TECHNICAL INFORMATION

Production capacity up to 200 KG / Hour

Dragee production options for small, big and desired forms

Cooling unit low to -25 celcius degree

Cooling tunnel and trimming station after forming rollers

Professional and quality smart production

ÇİKOLATA DİNLENDİRME KAZANLARI CHOCOLATE RESTING TANKS



TEKNİK ÖZELLİKLERİ

İstenilen KG'larda dinlendirme kazanları

Gerçek çikolataya göre sođutmalı servis tankları

Çift cidarlı ısıtma sistemleri

Özel mikserler

Fabrikara göre özel tasarımlar

TECHNICAL INFORMATION

Resting tanks for desired KG

Service Tanks with cooling for real chocolate

Double-jackets heating systems

Special mixers

Special design according to the factories

ÇİKOLATA DAMLA HATTI CHOCOLATE DROP LINE



TEKNİK ÖZELLİKLERİ

Bant genişliği 800-1200 mm

Malzeme 304 paslanmaz

Damla çikolata basma sistemi

Çift Fanlı soğutma grubu

TECHNICAL INFORMATION

Belt width 800-1200 mm

All material are stainless 304 quality

Depositor are servo control

Double fan cooling system



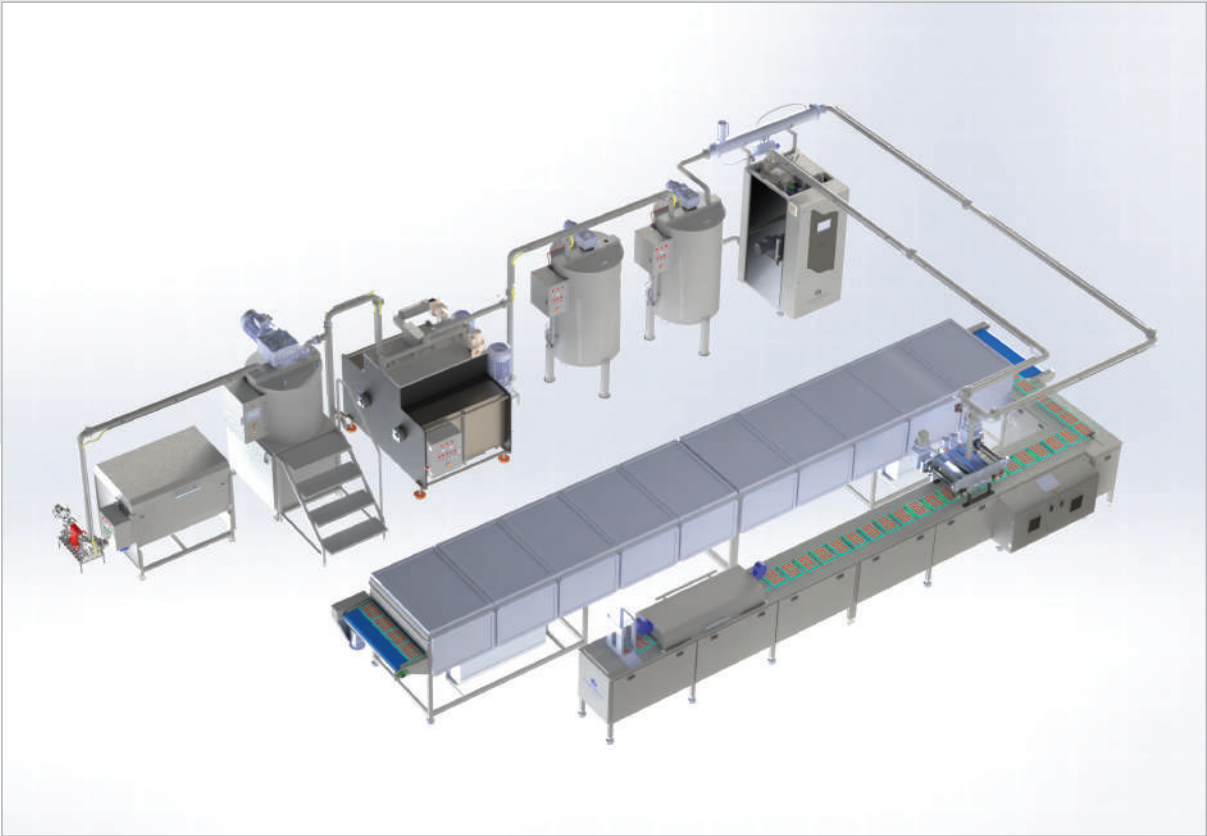





Eminoglu
Makina
em-dn 2000
rolling

Eminoglu
Makina
em-dn 2000

Eminoglu
Makina
em-dn 2000

EM





FABRİKA ALT YAPI SİSTEMLERİ

FACTORY SUBSTRUCTURE SYSTEMS

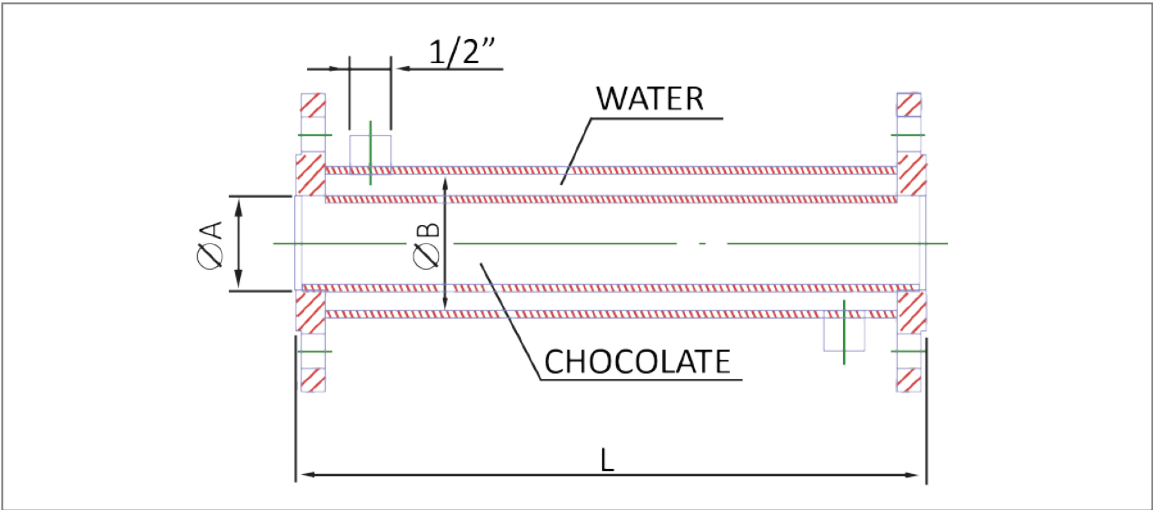
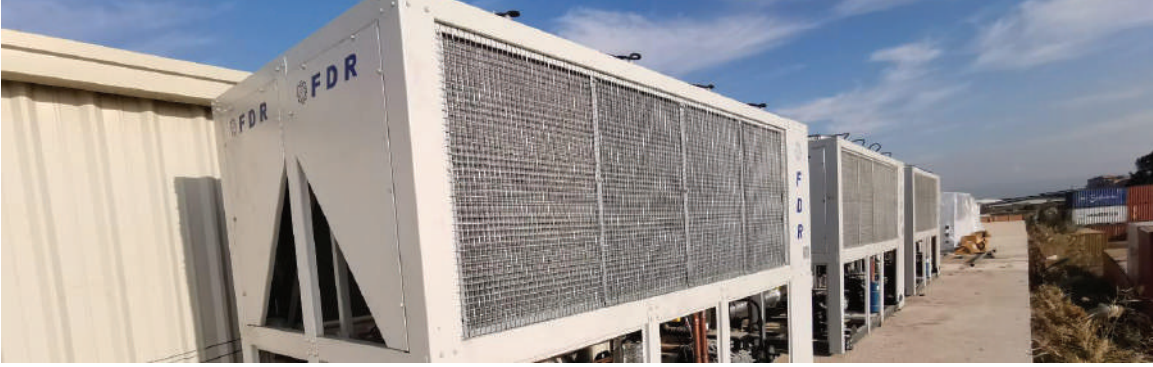

Ø A	Ø B	L	L	L	L	L
48.3	76.2	250	500	1000	2000	3000
60.3	89.8	250	500	1000	2000	3000
89.8	114.3	250	500	1000	2000	3000
114.3	139.7	250	500	1000	2000	3000



Mıknatıs Filtresi
Magnet Filter



Cidarlı T
Jacketed T



Cidarlı Dirsek
Jacketed Elbow



Cidarlı Vana
Jacketed Valve